



Administration Office
410 S. Commercial Street • Neenah, WI 54956
Tel: (920) 751-6800 • Fax: (920) 751-5067

TO: Board of Education Members
Dr. Mary B. Pfeiffer, District Administrator

FROM: Kathy Davis, Assistant District Administrator of Business Services *KD*
Jonathan L. Joch, Director of Revenue Enhancements & Business Services Support *JLJ*
Andrew J. Thorson, P.E., Director of Facilities/Engineer *AT*

DATE: March 11, 2014

RE: Rocket Stadium Upgrades

At the October 16, 2012 Neenah Joint School District Board of Education Meeting, Mr. Andrew Thorson, Director of Facilities/Engineer brought forward a proposal on behalf of the Neenah High School Quarterback Club asking for approval of their general direction and more specific approval of design and construction of the press box. The press box was the only project requesting approval at the time because it was the only project that had developed enough detail for a clear representation of the project. The general direction of the club's projects (with corresponding priorities) was laid out as follows:

1. Press Box & Sound System
- 1A. New Entrance Archway
2. New Ticket Booth/Concessions/Restrooms/Team Room Building
3. New Fencing
4. New Lighting/Relamping

In the seventeen months since that proposal, the Neenah Joint School District has received a generous donation in the amount of \$100,000 from two individuals who wish to remain anonymous at this time. This money has been donated as a restricted donation specifically for the stadium entryway (including ticket booth, archway and associated paving) and will cover the cost in full. The Board has not yet approved advancing the new entryway project. We are seeking approval before completion of the press box and sound system the Board previously approved in October of 2012, based upon the restricted donation. Included with this memo are the drawings of the entryway for the Board's review.

We are recommending approval of the ticket booth and entry archway, as it aligns with District goals and objectives and will be an excellent addition to the football facilities at Neenah High School. If approved, the construction would begin and be completed this coming summer.

The Rocket Stadium Renovation Committee continues their ambition in order to raise money for the other parts of the project. We, along with members of the Rocket Stadium Renovation Committee, will be in attendance at the March 18, 2014 Board of Education meeting to go through the design and to answer any questions.



ENTRY RENDERING

12" = 1'-0"



Gries
Architectural Group Inc.

500 North Commercial Street
Neenah, Wisconsin 54956
Phone: 920-722-2445 Fax: 920-722-6605
www.griesarchitectural.com

©Copyright. This Print/Computer File
is The Exclusive Property Of
Gries Architectural Group, Inc.
Use Only For Purpose Which Loaned. Copying Or
Reproducing is Prohibited. Return Upon Request.

SITE MASTER PLAN FOR:
NEENAH HIGH SCHOOL
NEENAH, WISCONSIN

date: 03/12/14
job: 13-010

A-1



TICKET BOOTH RENDERING

1/2" = 1'-0"



Gries
Architectural Group Inc.

500 North Commercial Street
Neenah, Wisconsin 54956
Phone: 920-722-2445 Fax: 920-722-6605
www.griesarchitectural.com

©Copyright. This Print/Computer File
is The Exclusive Property Of
Gries Architectural Group, Inc.
Use Only For Purpose Which Loaned. Copying Or
Reproducing is Prohibited. Return Upon Request.

SITE MASTER PLAN FOR:

NEENAH HIGH SCHOOL

NEENAH, WISCONSIN

date: 03/12/14

job: 13-010

A-2

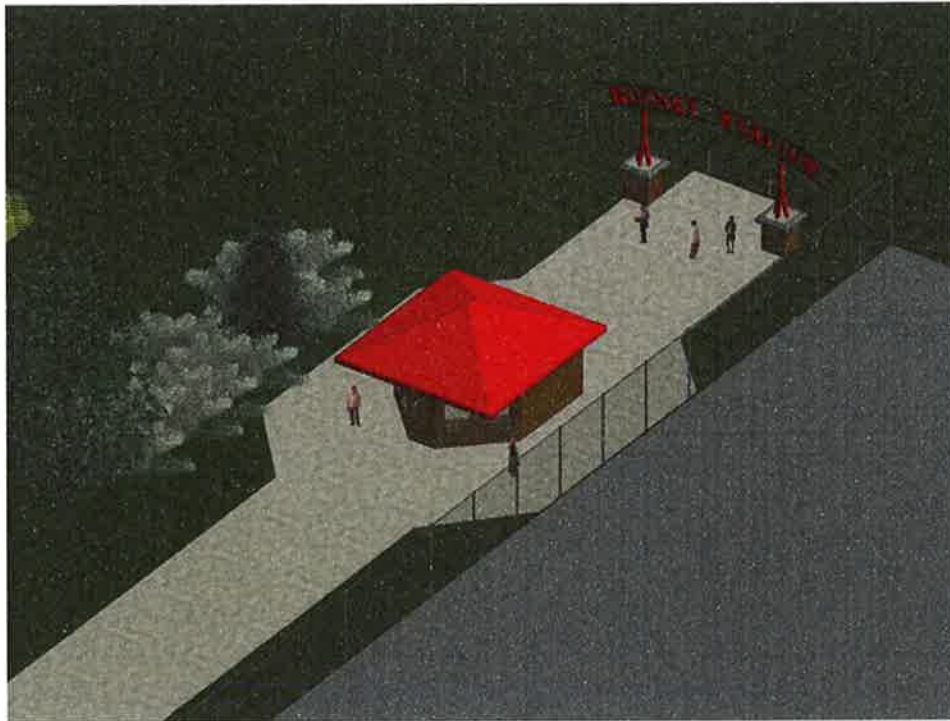

SITE PERSPECTIVE



Gries
 Architectural Group Inc.

500 North Commercial Street
 Neenah, Wisconsin 54956
 Phone: 920-722-2445 Fax: 920-722-6605
 www.griesarchitectural.com

©Copyright. This Print/Computer File
 Is the Exclusive Property Of
 Gries Architectural Group, Inc.
 Use Only For Purpose with License. Copying Or
 Reproducing is Prohibited. Return Upon Request.

SITE MASTER PLAN FOR:
NEENAH HIGH SCHOOL
 NEENAH, WISCONSIN

date: 03/12/14
 job: 13-010

A-3

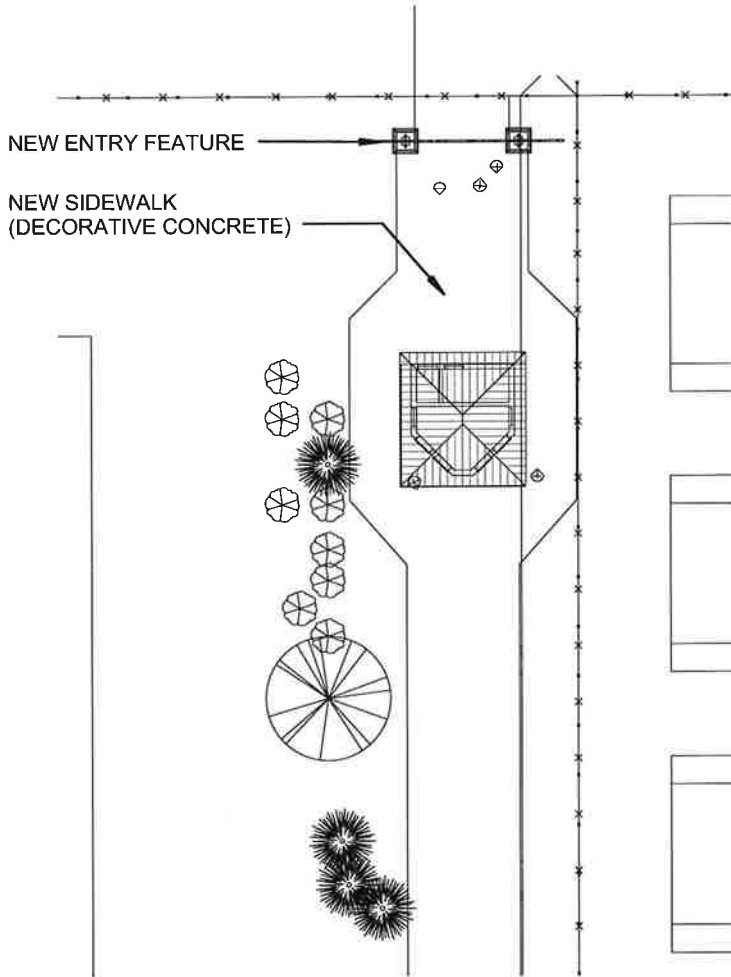

ENTRY SITE PLAN

1" = 30'-0"



Gries
Architectural Group Inc.

500 North Commercial Street
Neenah, Wisconsin 54956
Phone: 920-722-2445 Fax: 920-722-6605
www.griesarchitectural.com

©Copyright. This Print Computer File
is the Exclusive Property of
Gries Architectural Group, Inc.
Use Only For Purpose Which Licensed. Copying Or
Reproducing is Prohibited. Return Upon Request.

SITE MASTER PLAN FOR:
NEENAH HIGH SCHOOL
NEENAH, WISCONSIN

date: 03/12/14
job: 13-010

A-4

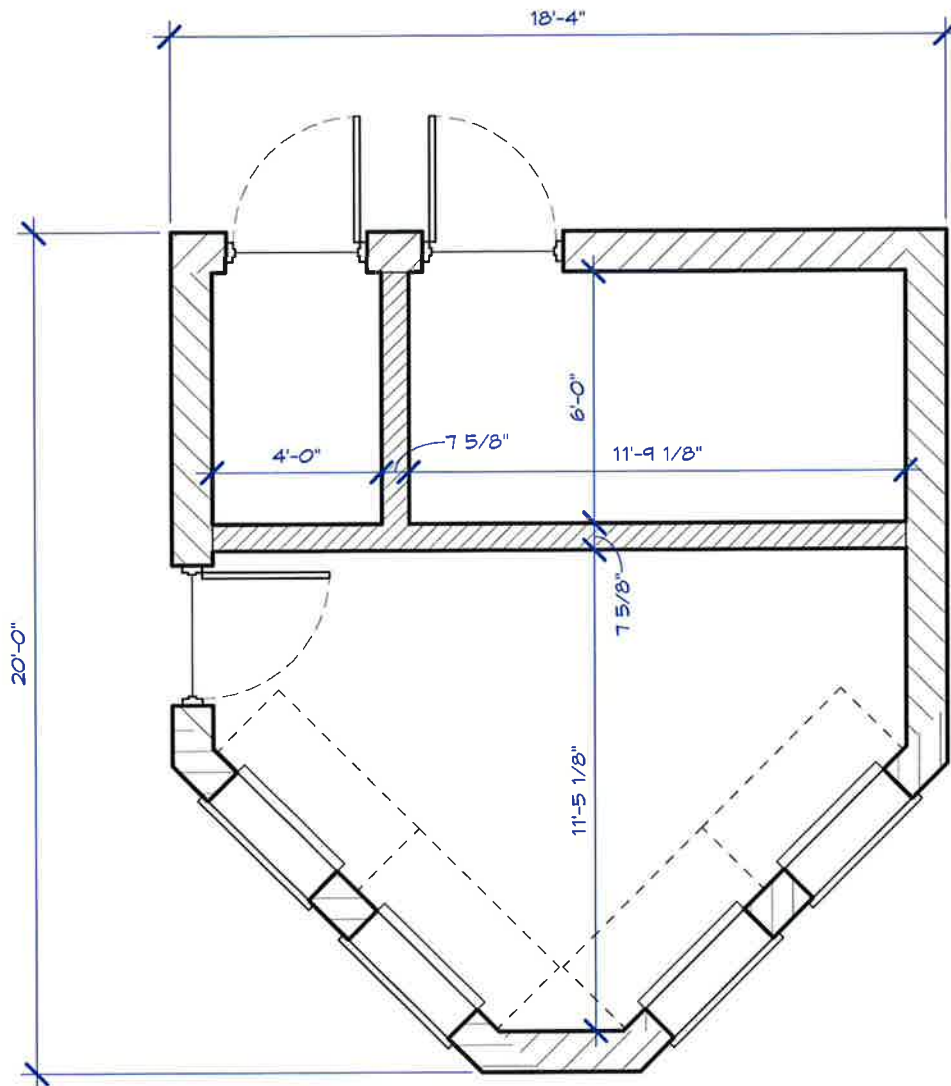

TICKET BOOTH PLAN

1/4" = 1'-0"



Gries
Architectural Group Inc.

500 North Commercial Street
Neenah, Wisconsin 54956
Phone: 920-722-2445 Fax: 920-722-6605
www.griesarchitectural.com

©Copyright. This Print/Computer File
is the Exclusive Property of
Gries Architectural Group, Inc.
Use Only For Purpose Which Loaned. Copying or
Reproducing is Prohibited. Return Upon Request.

SITE MASTER PLAN FOR:

NEENAH HIGH SCHOOL

NEENAH, WISCONSIN

date: 03/12/14

job: 13-010

A-5